

Pine

# Bath Shower Mixer

**Article no.:** 171000000  
**Finish:** Chrome  
**Series:** Pine

**EAN no.:** 5708516814658



## Standard features:

- Ceramic cartridge
- Rub-Clean
- Scalding protection (38°C)
- Water consumption max.24/13 l/min
- Eco-Save water saving feature
- Standard 150mm centres
- With 3/4" wall plates & eccentric unions
- 1/2" connection for hand shower hose

## Product features

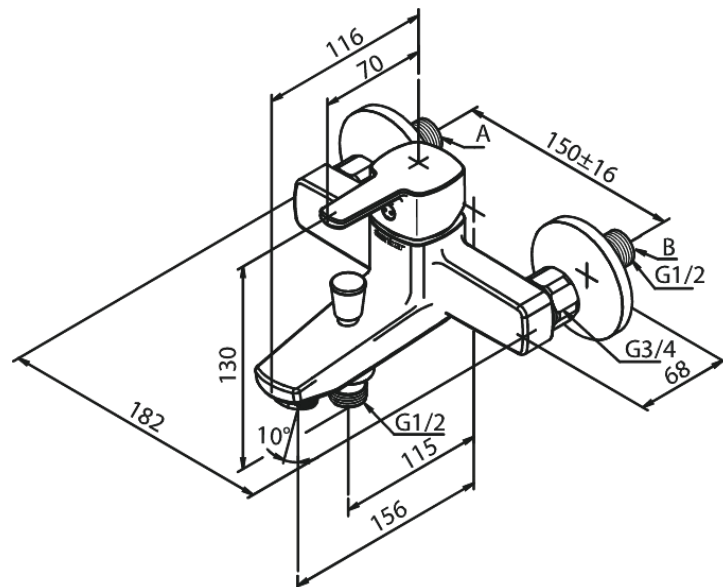

FM Mattsson Denmark ApS  
Hvidkærvej 48, 5250 Odense SV, DK-56416218

+45 88 33 00 34 damixa-international@fmmattsongroup.com

Mere information på [damixa.com](http://damixa.com)

**damixa**