

Slate

Shower Mixer

Article no.: 652007400
Finish: Chrome/Black
Series: Slate

EAN no.: 5708516736417



Standard features:

- Ceramic cartridge
- Scalding protection
- Water consumption max. 13 l
- Eco-Save water saving feature
- Standard 150mm centres
- With 3/4" wall plates & eccentric unions
- 1/2" connection for hand shower hose

Product features

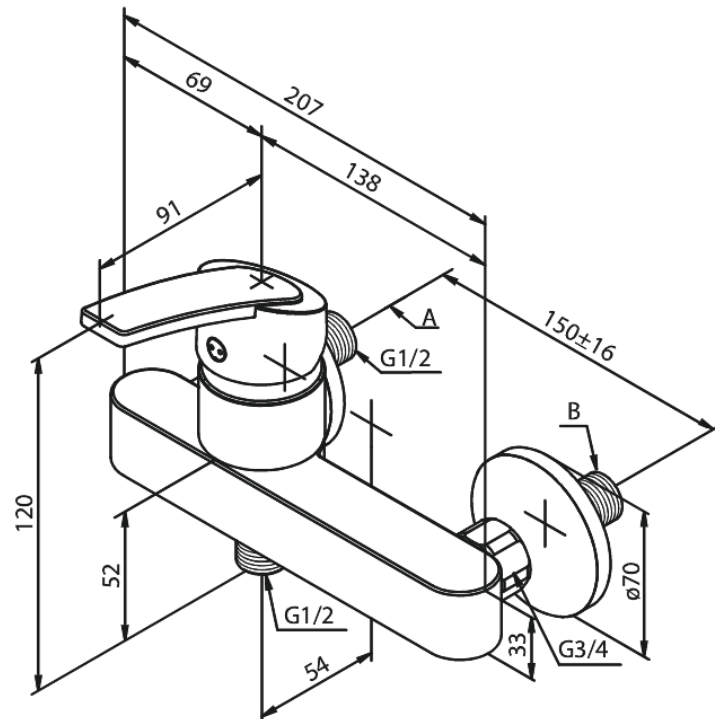
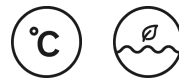

FM Mattsson Denmark ApS
Hvidkærvej 48, 5250 Odense SV, DK-56416218

+45 88 33 00 34 danmark@fmmattssongroup.com

Mere information på damixa.com

damixa